



Phil's Crane Hire Pty Ltd. ABN 90 105 040 926

28 Laurina Court, Elanora QLD 4221

Mobile: 0408 767 477

Fax: 07 5534 8622

Email: [philcrane@bigpond.net.au](mailto:philcrane@bigpond.net.au)

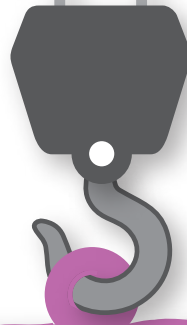

**FRANNA 15T**

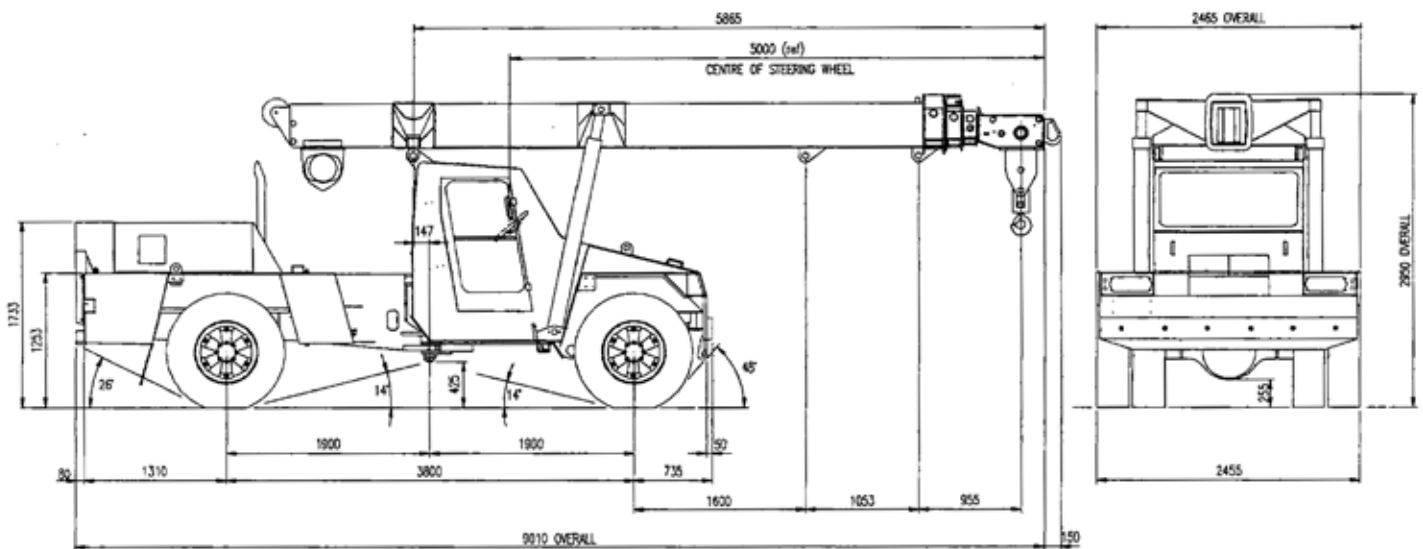

## Crane Dimensions

<b>Length (carrier)</b>	<b>5 925</b>
<b>Width</b>	<b>2 500</b>
<b>Height (with Boom)</b>	<b>2 950</b>
<b>Length Overall</b>	<b>9 010</b>
<b>Wheelbase</b>	<b>3 800</b>
<b>Front Axle Weight</b>	<b>6 000 kg</b>
<b>Rear Axle Weight</b>	<b>10 000 kg</b>

## RANGE DIAGRAM AT-15 SHOWING ALL LIFTING CONFIGURATIONS

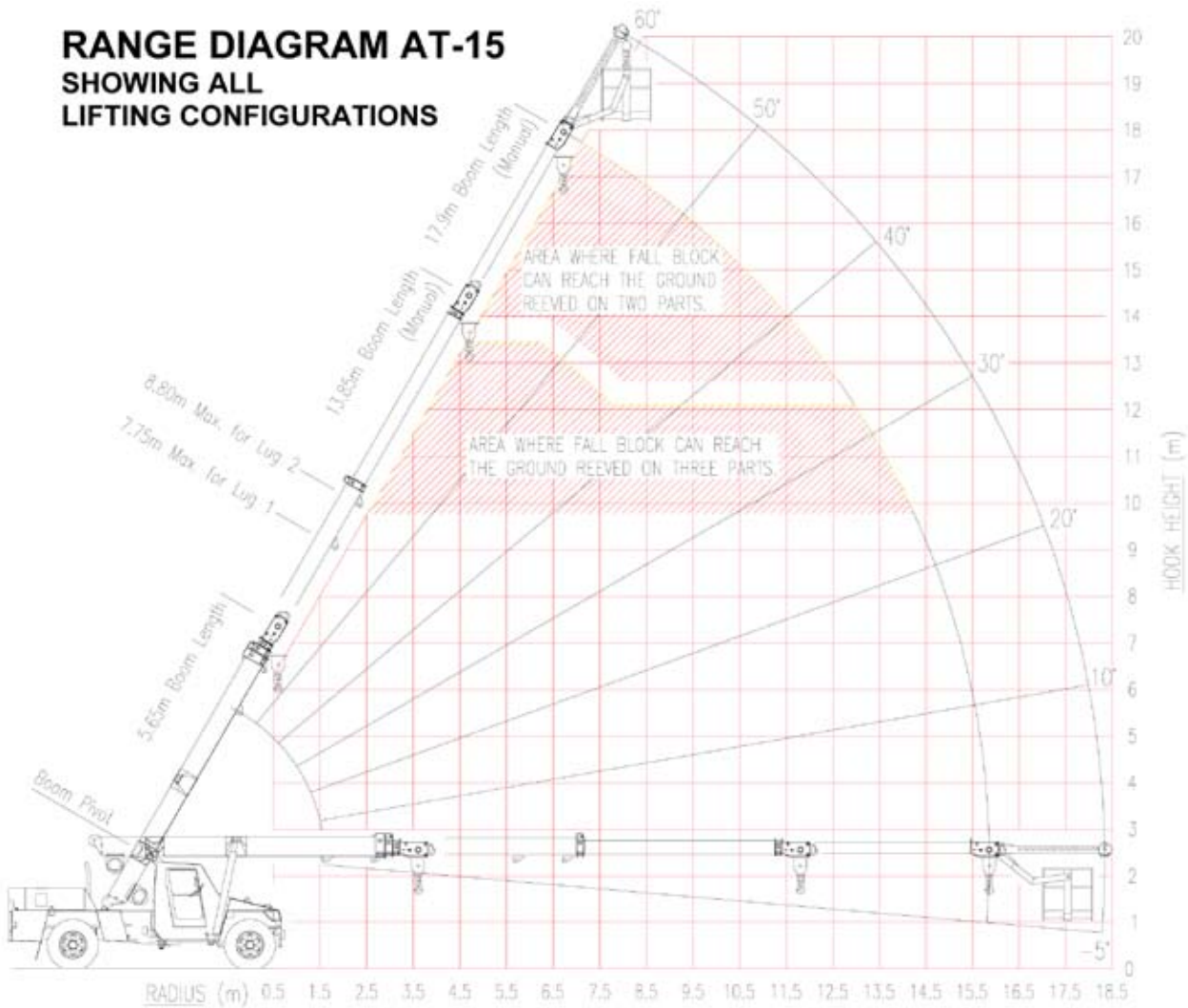

## Working Area Diagram

